

Seismic hazard of the Bayamo region (eastern Cuba) considering local soil typologies

Z.C. RIVERA⁽¹⁾, D. SLEJKO⁽²⁾, J. GARCÍA⁽¹⁾, L. PERUZZA⁽²⁾, A. REBEZ⁽²⁾ and M. SANTULIN⁽²⁾

⁽¹⁾ *Centro Nacional de Investigaciones Sismológicas, Santiago de Cuba, Cuba*

⁽²⁾ *Istituto Nazionale di Oceanografia e di Geofisica Sperimentale, Trieste, Italy*

(Received May 21, 2002; accepted September 19, 2003)

Abstract - Probabilistic seismic hazard for the Bayamo region (eastern Cuba) is computed taking into account the local soil characteristics, moving away from a broader regional seismic hazard assessment performed over the last few years. A detailed subdivision of local conditions, in terms of soil type categories, is proposed using the available geological map for the region. Two approaches for site-dependent hazard computation follow: the first implies the use of soil-related attenuation relations, the second applies soil amplification factors to the bedrock estimates. For both approaches European and American standards are considered and composed into a logic-tree structure. More precisely, a PGA attenuation relation calibrated on European data and another one calibrated on data from central America are used; PGA amplification factors for soil response are taken from the European and the U.S. building codes. Similarly, macroseismic intensity maps are computed using amplification increments from European and American literature. The final PGA map is, then, converted into a hazard map in terms of macroseismic intensity and compared with the map obtained using intensity data and soil-dependent amplification increments for intensity. A good agreement is obtained following the different approaches. For Bayamo, PGA values ranging from 0.17 to 0.23 g, corresponding to an intensity which goes from VIII to VIII-IX MSK, are expected for a 475-year return period. These values are fairly similar to those obtained using only macroseismic data, that range from VII-VIII to VIII-IX MSK. A local PGA hazard map like the one presented can be used for urban planning and detailed risk estimates, while the map in terms of macroseismic intensity gives an immediate rough estimate of the possible damage and can be used, then, for retrofitting policies.

Corresponding author: D. Slejko, Istituto Nazionale di Oceanografia e di Geofisica Sperimentale, Borgo Grotta Gigante 42c, 34010 Sgonico (Trieste), Italy; phone: +39 0402140248; fax +39 040327307; e-mail: dslejko@ogs.trieste.it

1. Introduction

The Island of Cuba is located on the North American plate on the boundary with the Caribbean plate and suffered several times, in the past, because of earthquakes. Historical documentation about earthquakes that struck the island can be found for the past five centuries, from the beginning of the Spanish colonisation; however, seismological investigations started only in 1855 when the first earthquake catalogue was published (Poey, 1855a, 1855b).

The first attempt to carry out a seismic hazard assessment for the island was based on macroseismic data (Alvarez, 1970); a detailed analysis on the seismicity of Cuba led to a seismic hazard map showing the intensity with a 100-year return period (Chuy and Rodriguez, 1980) and this map was revised following other earthquakes that hit Cuba (Chuy et al., 1983). Seismic hazard estimates for the whole country were computed using the Cornell (1968) probabilistic approach, in the McGuire's (1976) formulation, by Rubio (1985), while Alvarez and Bune (1985a, 1985b) assessed seismic hazard for eastern Cuba by using a modified version of the Riznichenko (1979) method and the attenuation relations by Alvarez and Chuy (1985). As the treatment of the information about seismogenesis was not uniform, a new study (Alvarez et al., 1991) devoted to the whole Cuban region became necessary. The results were a set of curves, tables, and maps published in the *Nuevo Atlas Nacional de Cuba* (1989). Chuy and Alvarez (1995) presented new hazard maps for the national building code collecting the results obtained by Orbera et al. (1990), Chuy et al. (1992), and González et al. (1993), for different regions of Cuba. Over the past years, estimates in terms of macroseismic intensity and peak ground acceleration (PGA) were obtained by probabilistic treatment (Rodriguez et al., 1997) for the whole of Cuba, with the use of a new unified earthquake catalogue of Cuba and its surroundings (Alvarez et al., 1999). Shedlock (1999) developed a hazard map for a 475-year return period for the wider Caribbean region in terms of PGA, and those results were taken by the Global Seismic Hazard Assessment Project (Giardini, 1999), pilot project of the International Lithosphere Program. More recently, García et al. (2003) estimated the seismic hazard for Cuba developing a seismogenic zonation for a broader region and considering different options for attenuation.

Bayamo is an important city located in the Granma province of eastern Cuba with about 130,000 inhabitants. It is close to the Oriente Fault Zone (Fig. 1a), which is the main seismic source affecting Cuba as the contact between the North American and the Caribbean plates occurs there. The first seismic event that hit Bayamo occurred in 1522; since then the city was damaged again twice (Chuy, 1999) in 1551 [intensity VIII Medvedev-Sponheuer-Karnik (MSK)] and in 1624 (VII MSK). More recently, earthquakes were felt in Bayamo in 1987 and 1988 (both with intensity V MSK) and on May 25, 1992 (VI MSK). Other investigations have been carried out recently for Bayamo: Torres (1990) performed the seismic microzonation of the city with soil characterisation on the basis of engineering-geological analogies and that study was improved by Fernández (1990). Site effects were investigated also by Chuy (1999) considering the macroseismic data collected for the 1987 and 1988 earthquakes. From the administrative point of view, the local authority financed specific studies (unpublished internal guidelines) on urban planning and preparedness against catastrophes. The seismic

microzonation of Bayamo was performed also by Rivera (2000), who compared the previous results from the engineering-geological approach with specific instrumental measurements. Those results were used by Vega et al. (2000) for assessing the seismic risk with vulnerability estimates provided by the census data. Consequently, the dynamic response of the main social features in the Granma province was evaluated by González et al. (2000). Further, Rivera (2001) computed the seismic risk for the city of Bayamo comparing the results of different approaches. It must be pointed out, however, that all the previously cited studies lack a robust hazard assessment for the Bayamo region.

The aim of the present work is to fill this gap, by improving the seismic hazard estimates through a probabilistic assessment for the Bayamo region which takes into account the soil typologies of the study area. The importance of a soil-dependent seismic hazard map has greatly increased over the past years especially at a regional scale (e.g. Field and the SCEC Working Group, 2000; Rebez et al., 2001). This work is preliminary to a complete seismic risk assessment, useful for urban planning, old building retrofitting, and earthquake preparedness.

2. Geological and tectonic framework of the Bayamo region

The Granma province in eastern Cuba, where the city of Bayamo is located (see Fig. 1a), is characterised by several significant active faults. The most important are the Cubitas, Cauto Nipe, Baconao and Oriente faults (Iturralde-Vinent, 1996). All these faults present a low to medium seismicity, with the exception of the last one, which belongs to the Bartlett-Caiman deep fault system. In fact, the regional seismicity depends on this fault: it represents the border zone between the North American and Caribbean plates.

The detailed seismic hazard assessment for the Bayamo region was performed according to the well-consolidated seismotectonic probabilistic approach (Cornell, 1968). This approach requires the space definition and the seismic characterisation of the seismogenic zones (SZs). The present study benefits from the results of García et al. (2003) as the same seismic model is here used: the seismogenic zonation (Fig. 1b) was derived from the previous studies of Cotilla et al. (1991), Chuy and Alvarez (1995), and Rodriguez et al. (1997). For the details, a short description of the SZs (Fig. 1b) influencing the seismic hazard of the Bayamo region is given in the following.

Cubitas (SZ18). It is considered the main SZ in central Cuba. It is a deep fault with a NW-SE direction and constitutes a portion of the marginal suture of the Cuban main fault. It is cut by some transversal faults. The main earthquake that occurred in this SZ is the Esmeralda event of 1974 ($M = 4.5$).

Cauto-Nipe (SZ19). It is associated to a system of SW-NE oriented faults, among which the principal ones are the Nipe - Guacanayabo and Cauto faults. Its seismicity is low with earthquakes of V MSK (in 1987 and 1988), VII MSK (in 1624), and VIII MSK (in 1551).

Baconao (SZ20). It is associated to the fault bearing the same name that skirts the north flank of Sierra de la Gran Piedra, with a SE-NW direction. This structure is active mainly at the intersection with the Bartlett-Cayman fault (Oriente Fault Zone).

Oriente (SZ28, SZ29, SZ30). The system is associated to the transcortical Bartlett-Cayman fault that is located in the southern sector of eastern Cuba and is more than 1600 km long, 50-100 km wide, and more than 50 km deep. It presents a predominant E-W direction and represents the North American plate margin. The major Cuban seismicity is located in this region with about 30 damaging earthquakes; twenty of which affected the area around Santiago de Cuba (M = 7.6 in 1766, M = 7.3 in 1852) and reached intensity IX MSK. Another strong event affected Pilon in 1992 and had a 6.8 magnitude.

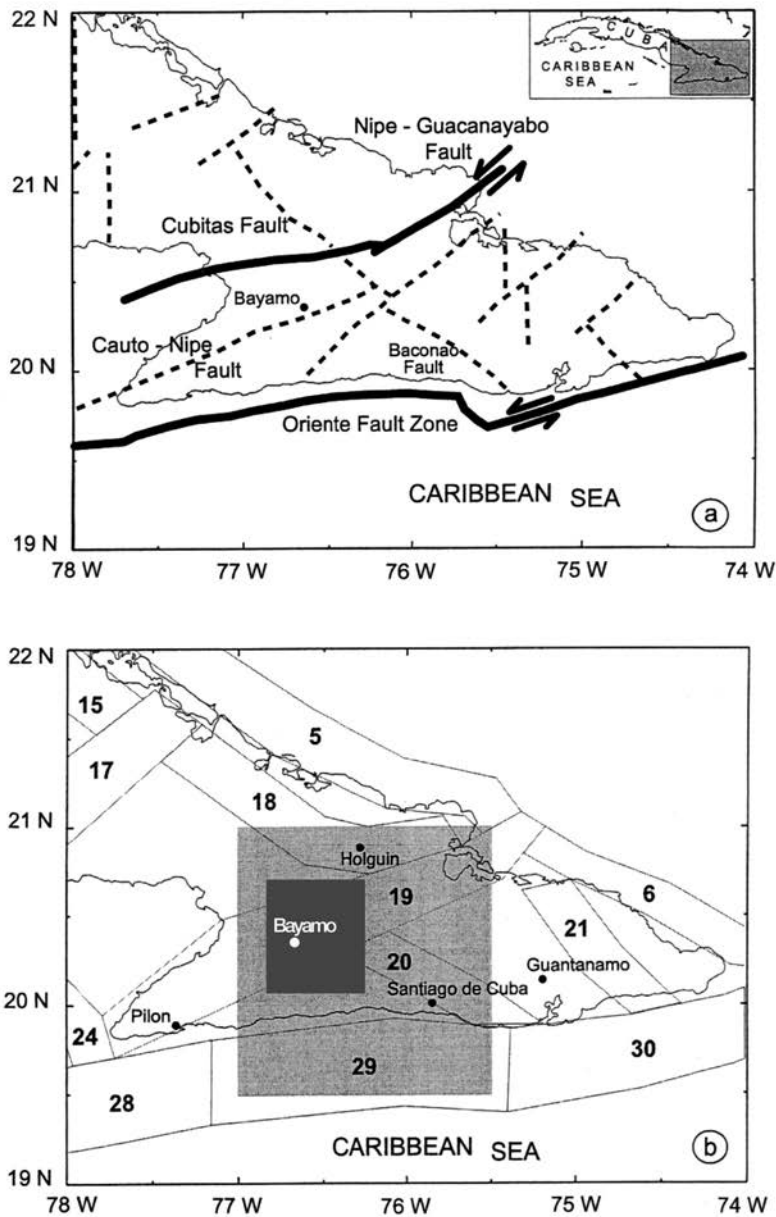

Fig. 1 - Seismotectonics of southern Cuba: a) main tectonic elements (modified from Iturralde-Vinent, 1996); b) seismogenic zonation (from García et al., 2003). The grey areas in Fig. 1b indicate southwestern Cuba (light grey) and the broader Bayamo region (dark grey).

It is possible to establish the differences within the complex geological and tectonic framework of the Bayamo territory, thanks to several evolution stages, taking into account the age, tectonic setting and geological characteristics. Two main geological structures can be seen in the Bayamo area from the morphostructural point of view (Nagy, 1983); each is characterised by its typical formation: the Sierra Maestra Anticlinorium and the Cauto Basin (see their features in Table 1 and Fig. 2a). Fundamentally, Paleogenic rocks of the island's arc constitute the first one, which is transitioning gradually to terrigenous and carbonate sequences, or both. The second one is constituted by typical sediments of the terrigenous-carbonatic neoplatform stage of Neogene-Quaternary age.

3. Soil dependent seismic hazard for the broader Bayamo region

Seismic hazard maps generally show the expected shaking at a reference soil (usually rock). Hazard maps that take into account the local response can have a great importance in urban planning (see Peruzza et al., 2001): to construct soil-dependent hazard maps it is necessary to quantify the local response on the basis of the regional geological features (Fig. 2).

Probabilistic seismic hazard assessment (PSHA) has been computed according to the standard approach of Cornell (1968) by the computer formulation of Bender and Perkins (1987).

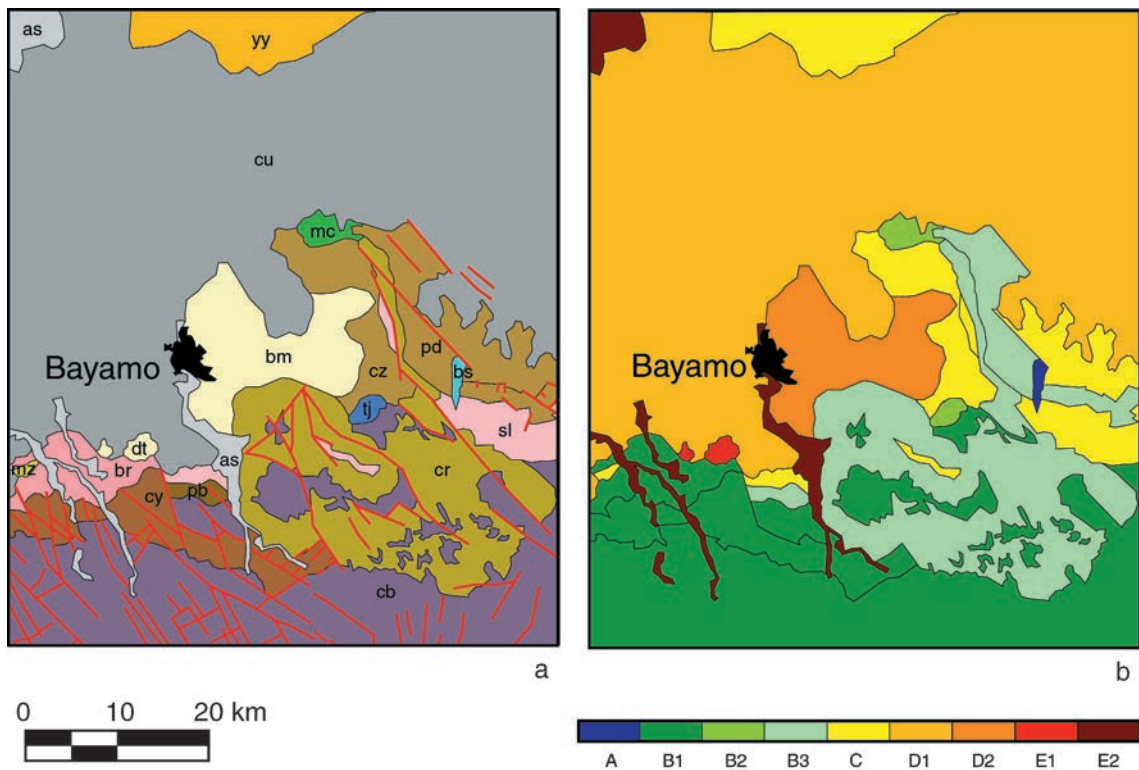

Fig. 2 - Geological characterisation of the broader Bayamo region, red lines indicate faults: a) regional geological map of the study area (see description in Table 1); b) soil characterisation according to Table 1.

Table 1 - Geological description (Nagy, 1983) of the Bayamo broader region and soil classifications and parameters.

Geological formation	Geological description	g. str.	Amb 96	Dah 95	EC 8	NEHRP	M62m	M62M	E&T85	cl.
bm = Bayamo	Clays, sands, polymictict grits, with nodulules of calcite, geothite and iron-manganese fragments	2	s	S	c	D	1.2	1.8	2.0	D2
br = Barrancas	Tuffites, volcanic and polymictict grits, clays, limestones with fragments of volcanic rocks, tuffs	1	r	R	a	B	0.2	1.3	0.3	B1
cb = El Cobre	Volcanites, volcanic sedimentary rocks, tuffs, lavas, tuffites, limestones, hypabyssal bodies, dikes	1	r	R	a	B	0.2	1.3	0.3	B1
cr = Charco Redondo	Organic detrital limestones with fossils and breccias	1	r	R	a	B	0.2	1.3	1.2	B3
cu = Cauto	Clays, muds, sands, polymictict gravels and conglomerates	2	s	S	c	D	1.0	1.6	2.0	D1
cy = Caney	Ash tuff alternations, tuffites, limestones, lapilli, lavas, briket intercalation	1	r	R	a	B	0.2	1.3	0.3	B1
cz = Camazán	Shallow water limestones, bio-detrital limestones with intercalation of marls and clays, gypsum occasionally	1	t	S	b	C	0.6	1.4	1.5	C
dt = Dátil	Polymictict briket mud	2	s	S	d	E	1.2	2.1	3.0	E1
mc = Micara	Massive clays, breccias, grits, limestones, marls, conglomerates, tuffs	1	r	R	a	B	0.2	1.3	0.8	B3
mz = Manzanillo	Detrital clayed limestones, gravels, sands, marls, calcareous clays, fossils	2	t	S	b	C	0.6	1.4	1.5	C
pb = Puerto de Boniato	Organic detrital limestones, marls with intercalation of silicon	1	r	R	a	B	0.2	1.3	1.2	B3
pd = Pedernales	Polymictict conglomerates cemented for clasts of diabases, gabbros, ultramafic rocks	2	r	R	a	B	0.2	1.3	1.2	B3
sl = San Luis	Polymictict grits, clays, marls, clayed limestones, sandy and polymictict conglomerates, dikes and basalts	1	t	S	b	C	0.6	1.4	1.5	D1
tj = Tejas	Tuffs, tuffaceous sandstone, schists, andesite dikes	1	r	R	a	B	0.2	1.3	0.8	B2
yy = Yayal	Micrite limestones, calcilutites, calcarenites, intercalation of silicon with radiolaria, clays, grits	2	t	S	b	C	0.6	1.4	1.5	C
as	Alluvial silts, vegetable covering, blocks, gravels, sands, clays	2	s	S	d	E	1.7	2.8	3.0	E2
bs	basalt	1	r	R	a	A	0.0	0.0	0.0	A

g. str. = geological structure: 1 = Sierra Maestra anticlinorium, 2 = Cauto basin;
 Amb96 = class according to Ambraseys et al. (1996): r = rock, t = stiff soil, s = soft soil;
 Dah95 = class according to Dahle et al. (1995): R = rock, S = soil;
 NEHRP = class and multiplicative term according to NEHRP (BSSC, 2001);
 EC8 = class according to the EC8 (CEN, 2002);
 M62m = minimum intensity increment according to Medvedev (1962);
 M62M = maximum intensity increment according to Medvedev (1962);
 E&T85 = intensity increment according to Evernden and Thomson (1985);
 cl. = classification used in this study.

As it is known, the Cornell (1968) approach is based on two working hypotheses: the earthquake recurrence times follow the Poisson distribution (the arrivals are, then, independent and the process is stationary in time) and the magnitude is exponentially distributed (the Gutenberg - Richter relation holds for magnitude and number of events in each magnitude class). In addition, the seismicity is considered uniformly distributed over the SZ. The Cornell (1968) method, then, needs the following input data: the SZ space definition, the seismicity rates (in terms of average number of earthquakes per magnitude interval), and the attenuation relation of the chosen parameter of motion. The seismicity of the previously described SZs has been modelled in terms of frequency - magnitude graphs computing the individual seismicity rates in 100 years taking into account different completeness periods for the different magnitude ranges [see a greater description in García et al. (2003)]. Probabilistic hazard maps of regional validity have, then, been generated for a 475-year return period (90% non-exceedence probability in 50 years, standard reference in seismic design) and for different soil types representing the median PGA value plus one standard deviation of the attenuation relation used.

In order to obtain a soil-dependent PGA map, the local soil characteristics, described by the different geological formations present in the area, have been associated to the main soil classifications available in literature. As a standard approach for constructing soil-dependent hazard maps is not codified and different methodologies can be followed, the logic-tree approach (Kulkarni et al., 1984; Coppersmith and Youngs, 1986) is applied here to take into account this epistemic uncertainty (McGuire and Shedlock, 1981; Toro et al., 1997). More

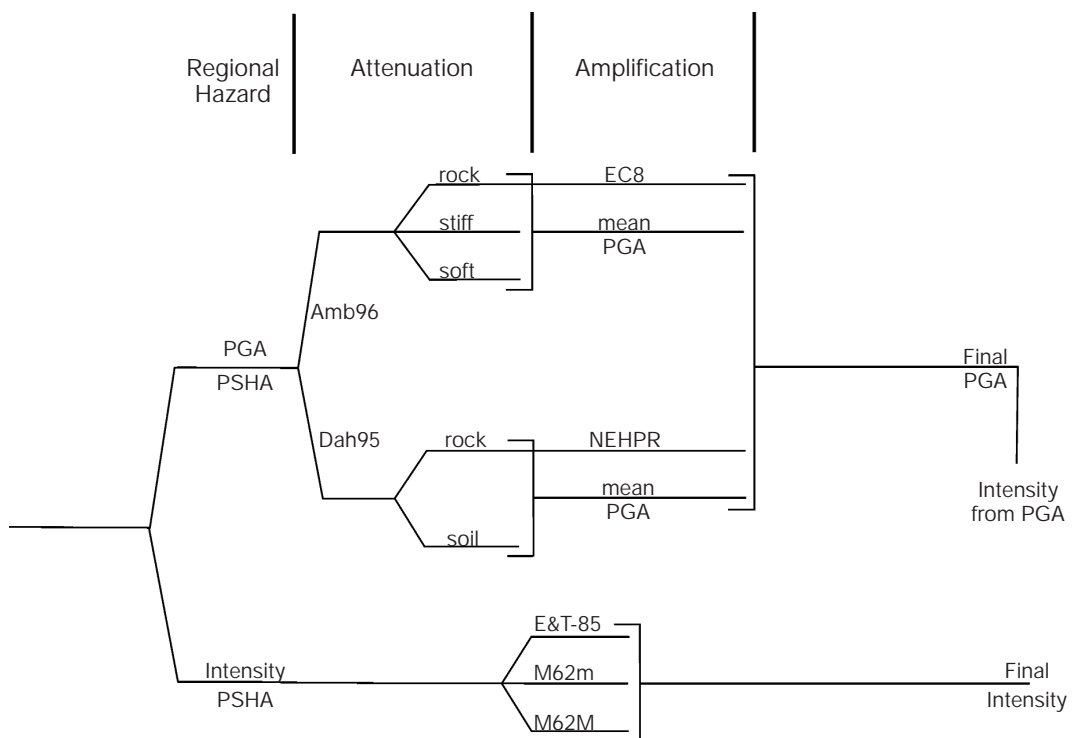

Fig. 3 - The logic tree used for the PGA hazard estimates and their comparison with the intensity estimates. The meaning of the acronyms is given in Table 1.

precisely, the logic tree (Fig. 3) has two branches: the first follows the European standards and the second the American ones. Each branch, moreover, makes two elaborations: the first is based on soil-dependent attenuation relations while in the second proper amplification factors are applied to the values referred to rock.

For the computation of the expected shakings, various information on the soil typology of all the different spatial sectors and the expected PGA have been associated with a GIS software.

3.1. European attenuation relations and soil amplification factors

The soil typology used in Europe is established in the European seismic code EC8 (CEN, 2002) and derives from the soil characterisation proposed in the U.S. by Boore et al. (1993). More precisely, the EC8 (CEN, 2002) provisions list four soil categories (see Table 2) according to the velocity of the shear waves in the upper 30 m (V_{30}).

The strong-motion attenuation relations of Ambraseys et al. (1996) are based on the EC8 soil categories and were calibrated on European earthquakes. The distance considered in the relation is the fault distance but only with strong earthquakes was it possible to compute this distance, in the other cases the epicentral distance was used. In the Cornell (1968) approach, seismicity is uniformly distributed over the areal seismogenic zone and radiated to the study point from the center of the mass of the small circular elements into which the seismogenic zone is subdivided. This distance is, then, neither the fault nor the epicentral distance but can be approximated to both. Not enough data were found to separate soft from very soft soils and, consequently, the attenuation relations are defined only for three different soil types, namely rock, stiff, and soft soil; the empirical curves corresponding to stiff and soft soils are, anyhow, very similar. In Table 1, the association between the geological formations in the Bayamo region and the Ambraseys et al. (1996) soil types is given and the resulting differentiation (the classification used in this study) is reported in Fig. 2b. It can be seen that the study region is characterised by a wide, northern area of soft soil, comprising also the city of Bayamo, while the rocks outcrop in the southern part of the study region, corresponding to the Sierra Maestra mountains.

Figs. 4a and 4b collect the PGA results from the PSHA obtained for the different soil types (rock and soft soil, the map for stiff soil is omitted here as it almost identical to the one for soft soil: the average stiff/rock ratio of the results obtained is 1.30 while for the soft/rock it is 1.32). The general shape is similar in both maps with the highest values located offshore; the expected

Table 2 - Comparison between the NEHRP (BSSC, 2001) and the EC8 (CEN, 2002) soil classifications. A_f is the amplification factor.

NEHRP				EC8			
Class	Description	V_{30}	A_f	Class	Description	V_{30}	A_f
A	Hard rock	>1500	0.8				
B	Rock	760-1500	1.0	a	Rock	>800	1.0
C	Soft rock	360-760	1.2	b	Stiff soil	360-800	1.2
D	Stiff soil	180-360	1.6	c	Soft soil	180-360	1.15
E	Soft soil	<180	2.5	d	Very soft soil	<180	1.35

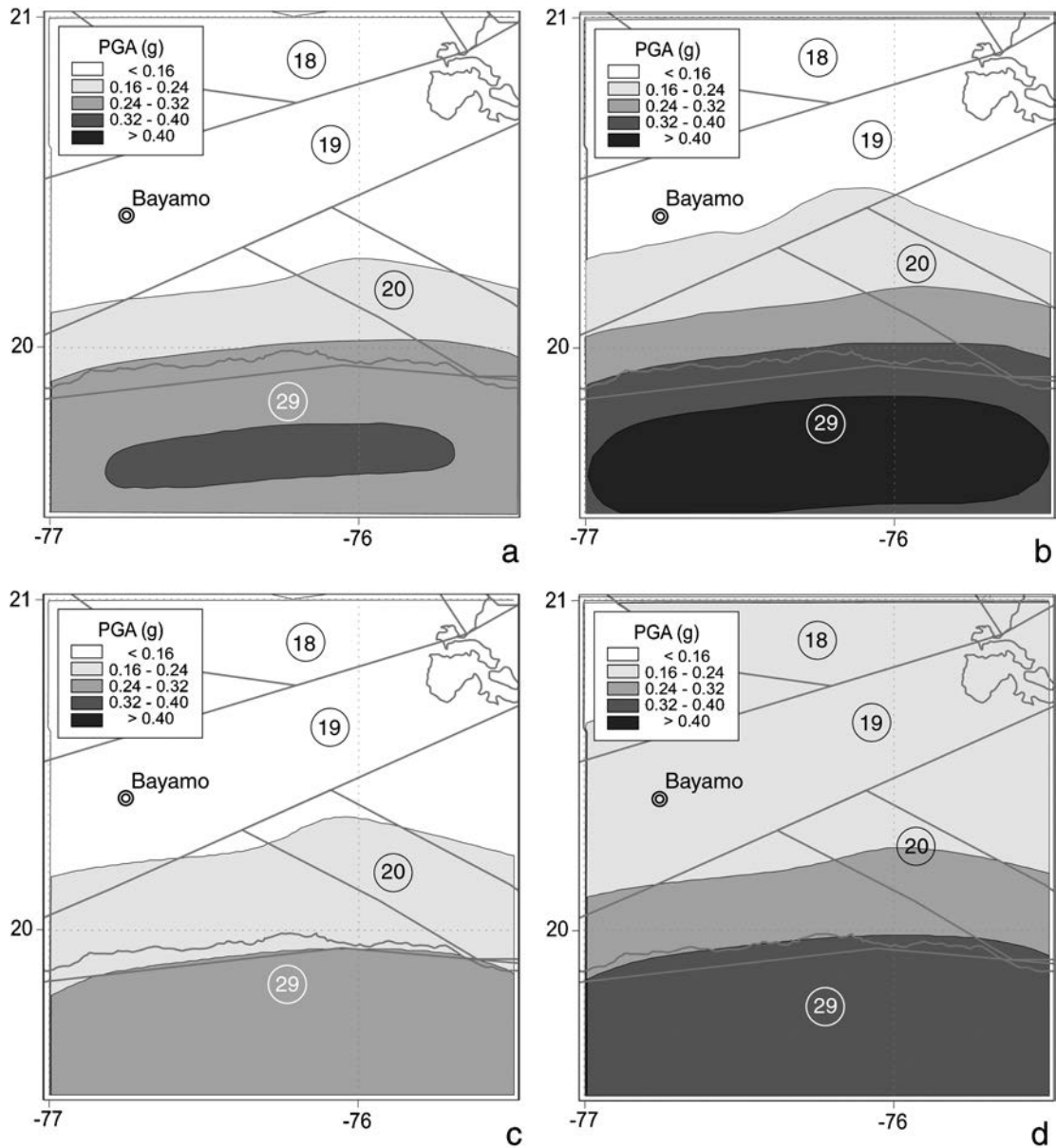

Fig. 4 - PGA (median values plus one standard deviation of the attenuation relation) with a 475-year return period for southwestern Cuba: a) Ambraseys et al. (1996) relation for rock; b) Ambraseys et al. (1996) relation for soft soil; c) Dahle et al. (1995) relation for rock; d) Dahle et al. (1995) relation for soil.

values are about 25% lower for rocky conditions. Focusing our attention on the city of Bayamo, the results are 0.12 g for rock and 0.15 g for both stiff and soft soils. It was easy at this point to obtain the PGA map according to the different Ambraseys et al. (1996) attenuation relations (Fig. 5a), simply by taking the proper PGA value according to the soil type (rock, stiff, or soft soil) of Fig. 2b. The expected shaking for the whole region varies between 0.11 and 0.23 g, with the highest values (exceeding 0.19 g) only along parts of some river valleys of the Sierra Maestra Anticlinorium. Practically no variation can be seen all around Bayamo (0.15 to 0.17 g).

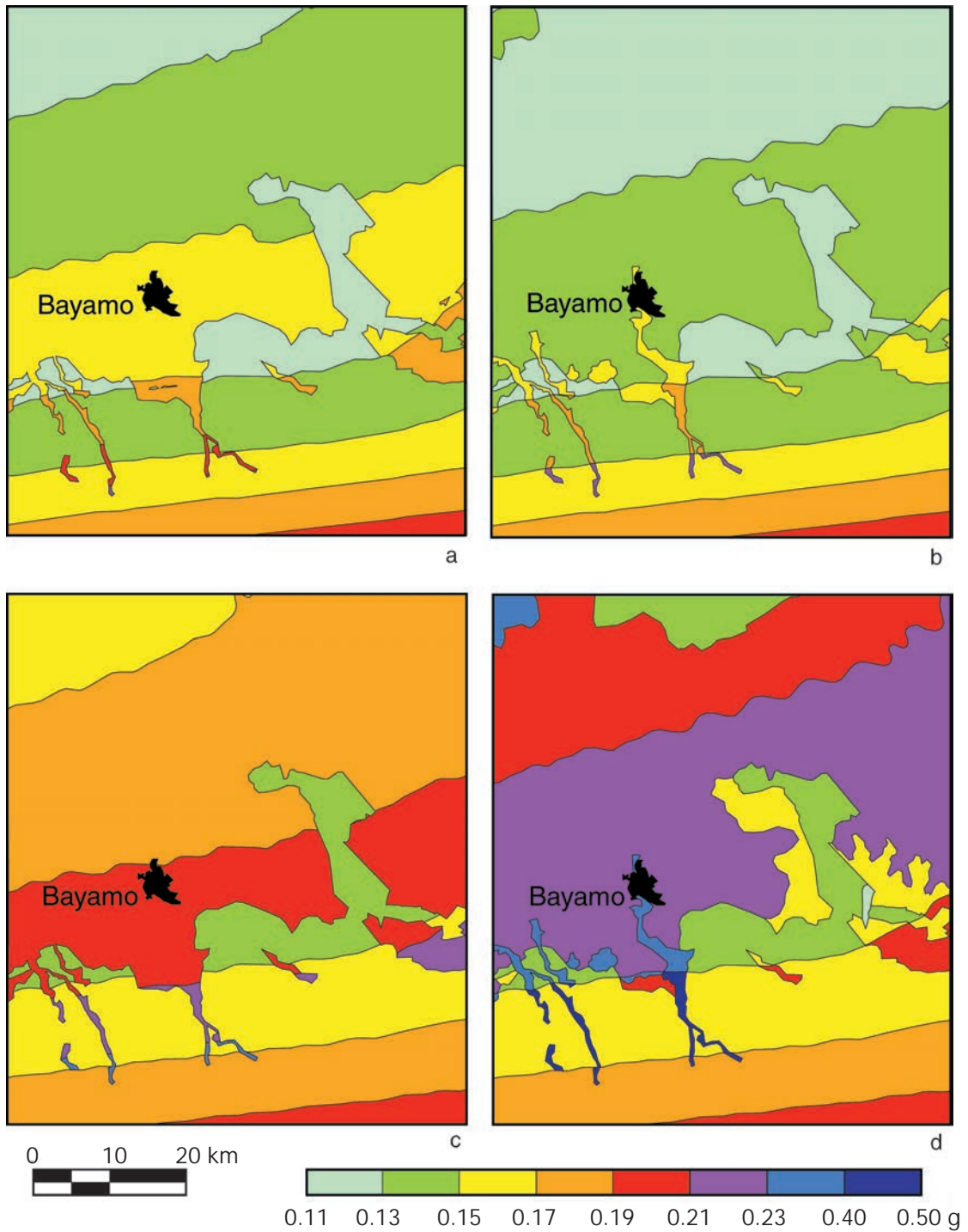

Fig. 5 - PGA (median values plus one standard deviation of the attenuation relation) with a 475-year return period computed according to the soil typologies of Fig. 2b for the broader Bayamo region: a) using European soil-dependent attenuation relations (Ambraseys et al., 1996); b) amplifying (CEN, 2002) the values for rock obtained by the Ambraseys et al. (1996) attenuation relation (Fig. 4a); c) using American soil-dependent attenuation relations (Dahle et al., 1995); d) amplifying (BSSC, 2001) the values for rock obtained by the Dahle et al. (1995) attenuation relation (Fig. 4c).

The European seismic code EC8 (CEN, 2002) defines the soil amplification factors for four soil types (rock, stiff, soft, and very soft soils) with respect to the PGA at the bedrock. V_{30} has been estimated according to the different geotechnical properties of the geological formations in the Bayamo region; thus, the soil classes and the related amplification factors have been assigned (Tables 1 and 2, and Fig. 2b) according to EC8 (CEN, 2002). Applying the proper soil amplification factors to the PGA estimates for rock (Fig. 4a) the results reported in Fig. 5b have been computed. The southern part of the map shows strong similarities to the map obtained by the different Ambraseys et al. (1996) attenuation relations (Fig. 5a); while lower values can now be seen in the central and the northern sectors. This is due to the fact that the EC8 amplification factor for soft soil is lower than that for stiff soil while this is only slightly reflected by the PGA attenuation relations (Ambraseys et al., 1996). When comparing the maps of Figs. 5a and 5b, for the whole territory, the difference remains lower than 0.04 g.

3.2. American attenuation relations and soil amplification factors

Strong-motion recordings are not available for Cuba, consequently, no local PGA attenuation relations are available either. Among the (few) attenuation relations calibrated on strong-motion data recorded in Central America (Douglas, 2003) the one proposed by Dahle et al. (1995) seems adequate for our needs. In fact, records from the subduction zones are a marginal part of the data set used and this attenuation relation considers two different soil types (rock and soil). The behaviour of the Dahle et al. (1995) attenuation relation is different from that of the Ambraseys et al. (1996) one, showing a slower PGA decay with distance, especially in the case of soil. This aspect is reflected in the hazard estimates obtained by the application of this latter relation (Figs. 4c and 4d): the average soil/rock ratio of the results obtained is 1.38. As a consequence, the soil-dependent PGA estimates are higher when applying the Dahle et al. (1995) attenuation relation (Fig. 5c) to almost everywhere in the study area rather than using the Ambraseys et al. (1996) one (Fig. 5a). The best agreement is encountered in the southernmost sector, where the PGA values are almost the same, while around Bayamo the difference is about 0.05 g. Focusing our attention on the city of Bayamo, the results are 0.14 g for rock and 0.19 g for soil.

The soil typology used in the U.S. is established in the building codes and derives from the soil characterisation proposed by Borchardt (1994) and formalised in the National Earthquake Hazards Reduction Program (NEHRP) provisions (BSSC, 2001). More precisely, the NEHRP (BSSC, 2001) provisions list five soil categories (see Table 2) according to the V_{30} . Similarly to the European methodology, the NEHRP (BSSC, 2001) soil classes have been associated to the geological formations in the Bayamo region, according to their estimated V_{30} (Table 1), and the related amplification factors have been used (Table 2). In this case, the PGA values on rock (Fig. 4c) were amplified with the coefficients of Table 2 giving the results reported in Fig. 5d. It can be seen that the expected PGA now reaches higher values than in the equivalent map with European parameters (Fig. 5b), or the map obtained by the Dahle et al. (1995) attenuation relation (Fig. 5c). In fact, the expected PGA now exceeds 0.21 g in a wide area around Bayamo

and approaches 0.5 g on the alluvial sediments along the river valleys. When comparing the maps in Figs. 5c and 5d, a good agreement can be noticed with a difference smaller than 0.06 g with the exception of the river valley, where the NEHRP (BSSC, 2001) amplification factors increase by more than 0.1 g the expected values.

3.3. PGA and macroseismic intensity average estimates

As there is no way of judging, which of the four previous maps (Fig. 5) is preferable, it was decided to evenly average the PGA estimates. The final PGA map (Fig. 6a) shows that most of the broader Bayamo region is characterised by values between 0.13 and 0.19 g. A wide sector SE of Bayamo displays lower values while higher values (larger than 0.21 g) are expected along all the river valleys, also that crossing Bayamo from north to south. The epistemic uncertainty associated with these estimates is about 0.04 g and is not considered in the following elaborations.

Seismic hazard maps, in terms of macroseismic intensity, were popular worldwide in the past, and still are, especially in countries where strong-motion data are not available. This is the

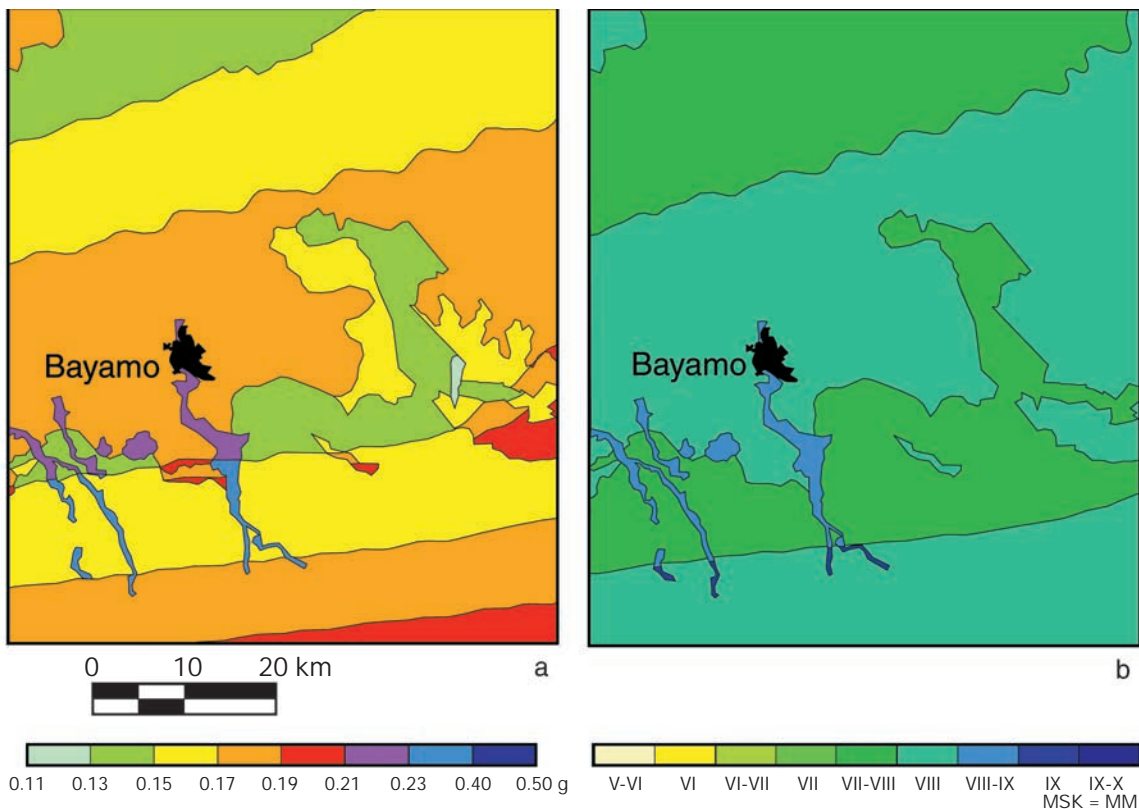

Fig. 6 - Seismic hazard maps for the broader Bayamo region: a) PGA (median values plus one standard deviation of the attenuation relation) with a 475-year return period computed averaging the different results of Fig. 5; b) macroseismic intensity (median values) with a 475-year return period computed by transforming (Murphy and O'Brian, 1977) the PGA values (Fig. 6a).

case of Cuba, where the hazard estimates used for defining the building code (Chuy et al., 1983) are expressed in macroseismic intensity on the MSK scale. The PGA values of Fig. 6a have been, therefore, transformed into intensity values by the inverse of the Murphy and O'Brian (1977) relation, which updates the previous results of Trifunac and Brady (1975). As the strong uncertainties introduced when using a linear relation between PGA and intensity are well known (Reiter, 1990), we can neglect the bias introduced when an inverse formula is used. The Murphy and O'Brian (1977) relation was calibrated for the IV to VIII Modified Mercalli (MM) intensity range, which roughly corresponds to the 0.018 to 0.18 g PGA range and can be extrapolated also up to X MM as the values it gives are in general agreement with the expected values estimated by previous relations [see details in Trifunac and Brady (1975)]. As the MM and MSK macroseismic scales can be considered roughly equivalent in the range of interest (Mueller and Mayer-Rosa, 1980), the relation is suitable for our purposes. The map so obtained is shown in Fig. 6b; values range now between VII-VIII and VIII-IX MM, with spots of IX MM along very limited parts of some river valleys. The shape of the equal intensity areas is now controlled by geological features, the maxima following the deposits of fluvial valleys. It must be pinpointed that these intensity estimates come from median PGA estimates plus one standard deviation of the attenuation relation while no uncertainty is generally considered in the hazard maps expressed in terms of intensity. Consequently, an average difference of one MM degree can be suggested when comparing intensity values coming from median PGA values plus one standard deviation and median PGA values. This rough estimate of one degree comes from the difference between the expected shakings with and without a standard deviation translated into intensity values by the Murphy and O'Brian (1977) relation.

4. Macroseismic intensity seismic hazard

The most recent intensity hazard map for Cuba (García et al., 2003) shows a regular pattern in the Bayamo region (Fig. 7) with median values increasing from VII MSK to VIII MSK going from NW to SE (as usual, no standard deviation on attenuation has been introduced). Although the attenuation relations used in that study are source-specific (i.e.: they have been calibrated on representative earthquakes of the SZs, and may differ significantly from one SZ to another), they are not obviously capable of taking into proper account the local response. Conversely, the intensity data set indirectly includes local site effects, and makes the attenuation relationships obtained equivalent to those calibrated for PGA on average soil conditions. Local soil amplification factors have, therefore, to be applied to intensity maps with special care, in order to avoid a double consideration of the soil type.

Local soil amplifications in terms of intensity have been proposed by different authors. Medvedev (1962) calculated intensity increments based on lithology of the geological units and the MSK scale; this technique was also used by Barosh (1969) and reconsidered by Evernden and Thomson (1985), who related the observed local intensity amplification (MM) to an age-dependent geological classification of outcrops in California. More recently, Astroza and Monge (1991) defined intensity increments on wide rock classes for central Chile. The Medvedev

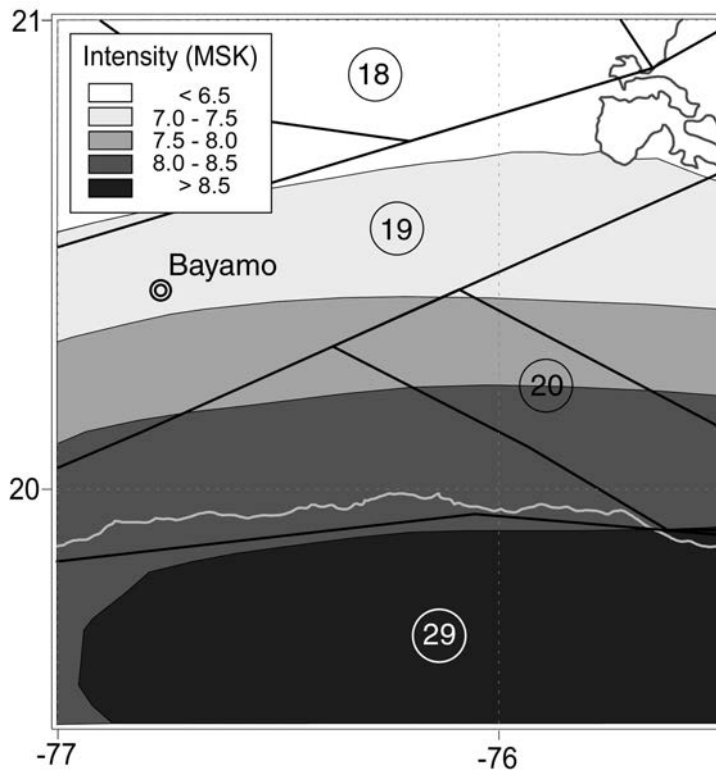

Fig. 7 - Regional macroseismic intensity (median values) with a 475-year return period for southwestern Cuba (from García et al., 2003).

(1962) and Evernden and Thomson (1985) classifications have been applied also in the present study considering the geological map (Fig. 2a) and the related amplification terms (Table 1 and Fig. 2a): these terms are increments and not multiplier factors like those used in the PGA cases. Note that the quantification of the intensity increments is based on limited data sets; Medvedev (1962) coefficients are given with quite a wide fork, and the association of the Cuban geological formations to the Californian lithotypes is necessarily approximated.

In order to apply the previously described increments to the intensity hazard map, we have to downgrade the regional results (Fig. 7) from average soil to reference rock conditions. We did this by computing the mean of the intensity increment values reported in Table 1 (namely 1.5), and by diminishing the regional values of the same amount. Then, we can again apply the amplification terms, depending on the site conditions, without risking a double consideration of the soil type. Fig. 8 strongly differs from the previously presented regional map (Fig. 7): in general, the values do not increase from north to south anymore and the most evident feature is given by the high intensity along the river valleys. The Medvedev (1962) increments (minimum in Fig. 8a, and maximum in Fig. 8b) show some differences with respect to the Evernden and Thomson ones (Fig. 8c) as the geological units have been classified using different criteria. Bayamo is located in an area where intensity ranges from VII MSK (in Fig. 8a) to VIII MSK (Fig. 8c), reaching values as high as IX MSK along the valley of the Bayamo river. The

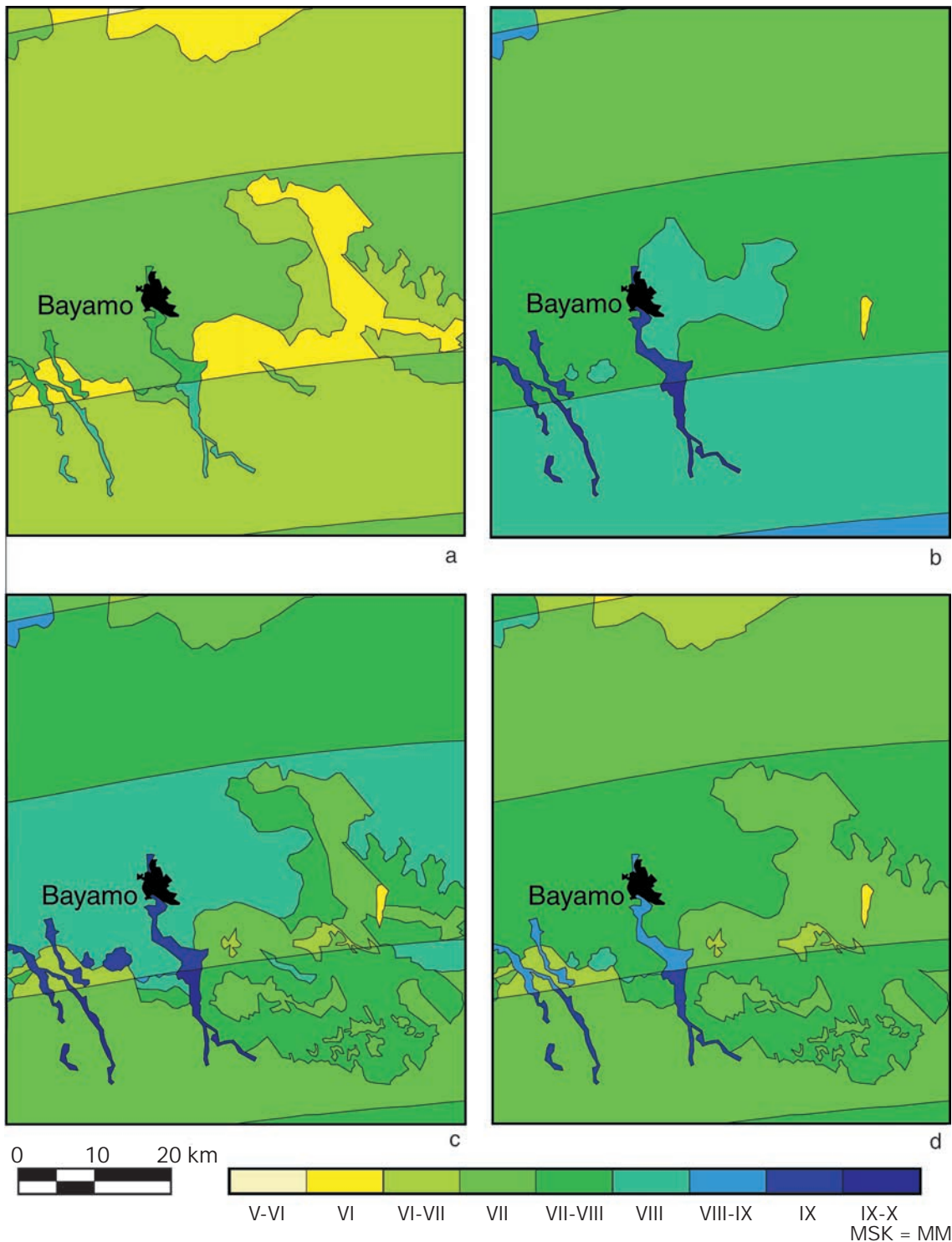

Fig. 8 - Macroseismic intensity (median values) with a 475-year return period for the broader Bayamo region: a) computed by amplifying the values for southwestern Cuba (Fig. 7) scaled for rock with the minimum increment (Medvedev, 1962); b) computed by amplifying the values for southwestern Cuba (Fig. 7) scaled for rock with the maximum increment (Medvedev, 1962); c) computed by amplifying (Evernden and Thomson, 1985) the values for southwestern Cuba (Fig. 7) scaled for rock; d) computed by averaging the previous results.

strongest effects are mapped in the upper part of the river valleys, with values of IX-X MSK: here the lateral contrast of intensity values is emphasized by the rocky outcrops of the Sierra Maestra anticlinorium.

The final intensity soil-dependent hazard map is given in Fig. 8d, where the values obtained according to the different authors and hypothesis are equally weighted. The predicted values are in reasonable agreement with the felt history of Bayamo, where the shakings of VIII MSK = MM refer to the 1551 and 1766 earthquakes, and damage was reported many times during the last centuries.

The agreement between the average intensity map (Fig. 8d) and that obtained transforming PGA results (Fig. 6b) is extremely good if we consider that, in the latter, the values are overestimated by about one MSK degree because of the influence of the standard deviation of the PGA attenuation relations.

This analysis demonstrates that great care must be taken into account when handling general amplification terms, especially for macroseismic intensities. The attenuation relationships, in fact, are obtained by regression of experimental data, where the macroseismic intensities, by definition, are not filtered from the local effects, such as soil and morphological amplifications. Further analyses in this field may improve the quantification of regional amplification factors.

5. Conclusions

In the present study, the local conditions have been introduced in the regional PSHA. For this two different approaches were followed: the use of differentiated attenuation relations and the application of amplification coefficients to hazard results referred to the bedrock. Furthermore, a comparison with hazard results, expressed in terms of macroseismic intensity has been made. This becomes, then, a global methodological example of PSHA at a regional to local scale.

The hazard maps presented are generated by using the detailed geological information available for the Bayamo region and can, consequently, be considered suitable for further studies towards a regional seismic risk assessment. Although the study region shows limited geological variations all around the main city, Bayamo, the improvement in hazard maps is significant when the local geology is considered (compare the standard hazard maps in terms of PGA of Fig. 4 with the final map in Fig. 6a, obtained by averaging the individual soil-dependent estimates). The approach presented here cannot be proposed as a valid substitute for detailed microzonation studies but can be used in the absence of detailed geophysical investigations for the rough identification of the expected shaking during earthquakes, especially when urban planning at an intermediate scale is needed.

The average PGA expected in the city of Bayamo is between 0.17 and 0.23 g for a 475-year return period (Fig. 6a), which corresponds to an intensity between VII and VIII MSK (Fig. 8d). These values are not very high but indicate the city of Bayamo as a city where seismicity can represent a natural hazard.

Acknowledgments. Two of the authors (Z.C. Rivera and J. García) undertook the present study in the framework of a fellowship of the International Centre for Theoretical Physics (Miramare, Trieste, Italy) at OGS.

References

- Alvarez H.; 1970: *Sismicidad de Cuba*. In: Atlas Nacional de Cuba. Instituto Cubano de Geodesia y Cartografía, La Habana, 20 pp.
- Alvarez L. and Bune V.I.; 1985a: *Seismic hazard in eastern Cuba*. Izvestiya Earth Physics, **21**, 733-741.
- Alvarez L. and Bune V.I.; 1985b: *A computer program for seismic hazard estimation*. In: Proc. 3rd Int. Symp. Analysis of Seismicity and Seismic Risk, Czech. Ac. Sc., Prague, pp. 432-439.
- Alvarez L. and Chuy T.; 1985: *Isoseismal model for Greater Antilles*. In: Proc. 3rd Int. Symp. Analysis of Seismicity and Seismic Risk, Czech. Ac. Sc., Prague, pp. 134-141.
- Alvarez L., Chuy T. and Cotilla M.; 1991: *Peligrosidad sísmica de Cuba. Una aproximación a la regionalización sísmica del territorio nacional*. Revista Geofísica, **35**, 125-150.
- Alvarez J.L., Chuy T.J., García J., Moreno B., Alvarez H., Blanco M., Exposito O., Gonzalez O. and Fernandez A.I.; 1999: *An earthquake catalogue of Cuba and neighboring areas*. Internal Report UNESCO-IAEA-ICTP IC/IR/99/1, Miramare, Trieste, 59 pp.
- Ambraseys N.N., Simpson K.A. and Bommer J.J.; 1996: *Prediction of horizontal response spectra in Europe*. Earthquake Engineering and Structural Dynamics, **25**, 371-400.
- Astroza M. and Monge J.; 1991: *Regional seismic zonation in central Chile*. In: Proc. 4th International Conference on Seismic Zonation, **3**, pp. 487-494.
- Barosh P.J.; 1969: *Use of seismic intensity data to predict the effects of earthquakes and underground nuclear explosions in various geological settings*. Bulletin 1279, U.S. Geological Survey, Denver, 93 pp.
- Bender B. and Perkins D.M.; 1987: *Seisrisk III: a computer program for seismic hazard estimation*. Bulletin 1772, U.S. Geological Survey, Denver, 48 pp.
- Boore D.M., Joyner W.B. and Fumal T.E.; 1993: *Estimation of response spectra and peak acceleration from western north American earthquakes: an interim report*. Open-File Report 93-509, U.S.G.S., Denver, 72 pp.
- Borcherdt R.D.; 1994: *Estimates of site-dependent response spectra for design (methodology and justification)*. Earthquake Spectra, **10**, 617-653.
- BSSC (Building Seismic Safety Council); 2001: *NEHRP recommended provisions for seismic regulations for new buildings and other structures*. Part 1 - Provisions, 2000 edition. BSSC, Washington D.C., 374 pp.
- CEN (Comité Européen de Normalisation); 2002: *Eurocode 8: design of structures for earthquake resistance*. Part 1: general rules, seismic actions and rules for buildings. Draft No 5, Doc CEN/T250/SC8/N317, CEN, Brussels, 100 pp.
- Chuy T.; 1999: *Macrosísmica de Cuba y su aplicación en los estimados de peligrosidad sísmica*. Master Thesis, Instituto de Geofísica y Astronomía, La Habana, 487 pp.
- Chuy T. and Alvarez L.; 1995: *Seismic hazard map of Cuba for the new building code of the Republic of Cuba*. Internal Report 1995/03/CONCE-CENAI, Ministry of Construction, La Habana, 19 pp.
- Chuy T., Alvarez L., Zapata J. and Gonzalez B.; 1992: *Investigaciones sismológicas complejas para el Complejo Hidroenergético Toa-Duaba*. Reporte de Investigación, Fondos del CENAI, 745 pp.
- Chuy T., Gonzalez B. and Alvarez L.; 1983: *On seismic hazard in Cuba*. Investigaciones Sismológicas en Cuba, **4**, 37-52.
- Chuy T. and Rodríguez M.; 1980: *The seismic activity of Cuba from historical date*. Investigaciones Sismológicas en Cuba, **1**, 5-7.

- Coppersmith K.J. and Youngs R.R.; 1986: *Capturing uncertainty in probabilistic seismic hazard assessments within intraplate environments*. In: Proceedings of the Third U.S. National Conference on Earthquake Engineering, August 24-28, 1986, Charleston, SC, Earthquake Engineering Research Institute, El Cerrito CA U.S.A., Vol. 1, pp. 301-312.
- Cornell C.A.; 1968: *Engineering seismic risk analysis*. Bull. Seism. Soc. Am., **58**, 1583-1606.
- Cotilla M., Bankwitz P., Franzke A., Alvarez L., González E., Díaz J., Gruenthal G., Pilarski J. and Arteaga F.; 1991: *Mapa sismotectónico de Cuba*. Escala 1:1000000. Comunicaciones Científicas sobre Geofísica y Astronomía, No. **23**, 49 pp., 1^{er} Anexo.
- Dahle A., Climent A., Taylor W., Bungum H., Santos P., Ciudad Real M., Linholm C., Strauch W. and Segura F.; 1995: *New spectral strong motion attenuation models for Central America*. In: Proceedings 5th International Conference on Seismic Zonation, Ouest Editions Presses Academiques, Nantes, Vol. 2, pp. 1005-1012.
- Douglas J.; 2003: *Earthquake ground motion estimation using strong-motion records: a review of equations for the estimation of peak ground acceleration and response spectral ordinates*. Earth-Science Reviews, **61**, 43-104.
- Evernden J.F. and Thomson J.M.; 1985: *Predicting seismic intensities*. In: Ziony J.I. (ed), Evaluating earthquake hazards in the Los Angeles region - An earth-science perspective, Professional Paper 1360, U.S. Geological Survey, Denver, pp. 151-202.
- Fernández B.; 1990: *Valoración de los efectos sísmicos por el método de analogías ingeniero-geológicas en la ciudad de Bayamo*. Internal Report 1990/05/CENAI, Santiago de Cuba, 25 pp.
- Field E.H. and the SCEC Working Group; 2000: *Accounting for site effects in probabilistic seismic hazard analysis of Southern California: overview of the SCEC phase III report*. Bull. Seismol. Soc. Am., **90**, S1-S31.
- García J., Slejko D., Alvarez L., Peruzza L. and Rebez A.; 2003: *Seismic hazard maps for Cuba and surrounding areas*. Bull. Seismol. Soc. Am., **93**, 2563-2590.
- Giardini D.; 1999: *The Global Seismic Hazard Assessment Program (GSHAP) - 1992/1999*. Annali di Geofisica, **42**, 957-974.
- González B., Chuy T., Alvarez L. and Rubio M.; 1993: *Estudios sismológicos complejos de Cuba Centro Oriental para el emplazamiento de objetivos nucleares*. Internal Report 1994/07/SEAN-MINBAS-CENAI, La Habana, 184 pp.
- González B., Oliva R., Arango E., García J., Perez L., Serrano M., Fernandez A., Marquez P., Vega I., Morejon G., Diaz R., Ortega L., Hernandez E., Rosa A., Seo K., Samano T. and Rodriguez V.; 2000: *Microtremor measurements for site response and vulnerability analysis in Cuba*. In: Proceedings of the Workshop to Exchange Research Information, Hakone Gora, Kanagawa, Japan, pp. 5-21.
- Kulkarni R.B., Youngs R.R. and Coppersmith K.J.; 1984: *Assessment of confidence intervals for results of seismic hazard analysis*. In: Proceedings of the Eighth World Conference on Earthquake Engineering, July 21-28, 1984, San Francisco CA U.S.A., Prentice-Hall Inc., Englewood Cliffs NJ U.S.A., Vol. 1, pp. 263-270.
- Iturralde-Vinent M. (ed); 1996: *Ofiolitas y arcos volcánicos de Cuba, First Contribution of IGCP Project 364 "Geological Correlation of Ophiolites and Volcanic Arc Terrains in the Circum Caribbean Region"*. Museo Nacional de Historia Natural, La Habana, 265 pp.
- McGuire R.K.; 1976: *Fortran computer program for seismic risk analysis*. U.S.G.S. Open File Report 76-67, 92 pp.
- McGuire R.K. and Shedlock K.M.; 1981: *Statistical uncertainties in seismic hazard evaluations in the United States*. Bull. Seismol. Soc. Am., **71**, 1287-1308.
- Medvedev J.; 1962: *Engineering seismology*. Academia Nauk Press, Moscow, 260 pp.
- Mueller S. and Mayer-Rosa D.; 1980: *The new seismic hazard maps for Switzerland*. Revista Geofísica, **13**, 7-19.
- Murphy A.J. and O'Brien L.J.; 1977: *The correlation of peak ground acceleration amplitude with seismic intensity and other physical parameters*. Bull. Seismol. Soc. Am., **67**, 877-915.
- Nagy E.; 1983: *Contribución a la geología de Cuba Oriental*. Instituto de Geología y Paleontología, Acc. Editorial Científico Técnica, La Habana, 273 pp.

- Nuevo Atlas Nacional de Cuba; 1989: *Sección III: Características Geofísicas*. Instituto de Geografía de la Academia de Ciencias de Cuba, Instituto Cubano de Geodesia y Cartografía and Instituto Geográfico Nacional (España), La Habana, 16 pp.
- Orbera L., González B., Chuy T. and Oro J.; 1990: *Investigación sísmica en la región de emplazamiento del Centro de Investigaciones Nucleares*. Internal Report 1990/08/SEAN-CENAI, La Habana, 344 pp.
- Peruzza L., Rebez A. and Slejko D.; 2001: *Seismic hazard mapping for administrative purposes*. Natural Hazards, **23**, 431-442.
- Poey A.; 1855a: *Tableau chronologique des tremblements de terre ressentis a l'île de Cuba de 1551 a 1855*. Ghautier-Villars Iprimeur Libraire, Paris, 53 pp.
- Poey A.; 1855b: *Supplemen au tableau chronologique des tremblements de terre ressentis a l'île de Cuba de 1551 a 1855*. Ghautier-Villars Iprimeur Libraire, Paris, 45 pp.
- Rebez A., Carulli G.B., Codermatz R., Cucchi F., Peruzza L. and Slejko D.; 2001: *Soil type dependent spectral seismic hazard in Friuli - Venezia Giulia (NE Italy)*. Boll. Geof. Teor. Appl., **42**, 121-138.
- Reiter L.; 1990: *Earthquake hazard analysis: issues and insights*. Columbia University Press, New York, 252 pp.
- Rivera Z.; 2000: *Microzonacion sismica de la ciudad de Bayamo MN*. In: Red de Estaciones Sismologicas en Cuba, Editorial Academia, La Habana, pp. 61-66.
- Rivera Z.; 2001: *Riesgo sísmico para el planeamiento urbano en la ciudad de Bayamo*. Master Thesis, Instituto Superior Minero Metalúrgico, Moa, 90 pp.
- Riznichenko Yu.V. (ed); 1979: *Seismic shakeability of the U.S.S.R*. Nauka, Moscow, 184 pp., in Russian.
- Rodriguez M., Alvarez L. and García J.; 1997: *Estimaciones probabilísticas de la peligrosidad sísmica en Cuba*. Revista Geofísica, **47**, 46-77.
- Rubio M.; 1985: *The assessment of seismic hazard for the Republic of Cuba*. In: Proc. 3rd Int. Symp. Analysis of Seismicity and Seismic Risk, Czech. Ac. Sc., Prague, pp. 424-431.
- Shedlock K.M.; 1999: *Seismic hazard map of North and Central America and the Caribbean*. Annali di Geofisica, **42**, 977-999.
- Trifunac M.D. and Brady A.G.; 1975: *On the correlation of seismic intensity scales with the peaks of recorded strong ground motion*. Bull. Seismol. Soc. Am., **65**, 139-162.
- Toro G.R., Abrahamson N.A. and Schneider J.F.; 1997: *Model of strong motions from earthquakes in central and eastern North America: best estimates and uncertainties*. Seismol. Res. Lett., **68**, 41-57.
- Torres D.; 1990: *Esquema de microzonación sísmica de la ciudad de Bayamo por el método de analogías ingeniero-geológicas*. Master Thesis, Instituto Superior Minero Metalúrgico, Moa, 75 pp.
- Vega I., Artímez J. and Rodríguez D.; 2000: *Valoración del riesgo sísmico de la ciudad de Bayamo*. In: Sismos Perceptibles, Peligro y Vulnerabilidad Sísmica en Cuba, Editorial Academia, La Habana, pp. 93-102.