

## Accelerometers for CHAMP, GRACE and GOCE space missions: synergy and evolution

P. TOUBOUL, E. WILLEMENOT, B. FOULON and V. JOSSELIN

*Onera, Châtillon, France*

(Received October 4, 1998; accepted August 5, 1999)

**Abstract.** The STAR ultra-sensitive space accelerometer, based on the accurate electrostatic levitation of a parallelepiped proof-mass, is integrated at the center of the mass of the CHAMP satellite to be launched in 1999. STAR will perform the measurement of the non-gravitational accelerations which perturb the low-altitude orbit to be finely determined from the on-board GPS receiver, aiming at the recovery of the Earth's gravity field. The operation, design and technology of the accelerometer are well suited for optimization of the measurements provided for different mission performance requirements and environments. The Super-STAR instrument is designed keeping in view the two GRACE satellites, with a reduced full-scale range, and a resolution ten times better, leading to  $10^{-10} \text{ ms}^{-2}$  over an 1 Hz bandwidth. The launching of the GRACE satellites is scheduled for 2001 and the GOCE project is a good candidate for a follow-on mission. The GOCE's on-board gradiometer can be composed of a very stable carbon-carbon structure with similar electrostatic accelerometers : taking advantage of the fine active thermal control of the instrument case and of the drag-free compensation system of the satellite, a few  $10^{-3}$  Eötvös can be reached at an altitude as low as 250 km.

### 1. Introduction

Numerous space applications require dedicated accelerometers with ranges and sensitivities optimized for the in-orbit environment. For the microgravity experiments performed on board the shuttle or envisaged on the International Space Station, the quasi-continuous residual acceleration and the vibration levels of the platforms carrying the experimental devices have to be surveyed or controlled even better (Nati et al., 1996).

Fundamental physics experiments, researching on new interactions or on the direct observation of gravity waves, require measurements of very weak accelerations that can only be

---

Corresponding author: P. Touboul; Onera, Avenue de la Division Leclerc 29, F-91420 Châtillon, France; phone: +33 1 4673 4832; fax: +33 1 4673 4148; e-mail: touboul@onera.fr

performed in a very soft environment that can be provided by dedicated satellites with drag compensation systems. This is the case of the LISA mission, jointly studied by NASA and ESA, which envisages the triangle formation of three drag-free satellites in an heliocentric orbit : a Michelson laser interferometer is then constituted between the masses of the inertial sensors integrated at the center of the satellite; the fluctuations of the propagation time of the laser light should be representative of the gravity waves between the masses, which have to fall in a pure gravitational motion with a resolution of better than a femto-g (Folkner, 1998). The test of the Equivalence Principle with an accuracy of  $10^{-15}$  is also proposed by one of the authors considering ultra-sensitive differential accelerometers including two test-masses made of different materials (Touboul, 1998).

In the field of Earth or Planet observations, two main applications of the ultra-sensitive accelerometers merge. First, the measurement of the surface forces acting on the satellite provide information on the atmospheric density variations and on the high-altitude winds. It also provides information on the radiation pressure from the sun or from the planet (albedo, infra-red emission). This was the case of the CASTOR D5B satellite with the CACTUS accelerometer in orbit around the Earth (Boudon, 1978) or more recently with another triaxial accelerometer system (Marcos and Fordes, 1985). Missions aiming at the analysis of the Mars atmosphere have been recently performed (Keating et al., 1998; Bougher et al., 1998) and new ones are proposed for the next ten years, involving, in particular, accelerometers for the atmospheric drag and wind measurements (Chassefière et al., 1998).

The second major objective rests in the global and accurate recovery of the gravity field of the Earth or of another planet. The simpler way is to observe the satellite orbit, like in CHAMP. A low altitude is needed since altitude is a filter for small wavelength gravity anomalies. But at a low altitude, non-gravitational effects much perturb the orbit, mainly because of the atmospheric drag which is preponderant with respect to the radiation pressure for an altitude lower than about 700 km, depending on the satellite mass and shape and the sun's activity. So, to eliminate the non-gravitational effects, an accelerometer is integrated at the satellite center of gravity in order not to be disturbed by the centrifugal and the angular accelerations.

For the determination of the higher harmonics of the Earth's gravity potential, it is proposed to compare the relative velocity and orbit of two identical satellites with one accelerometer on board each: the satellite tracking is performed by a micro-wave or a laser device. In the GRACE mission, the two satellites to be launched in 2001 have the same circular orbit at a decreasing altitude from 500 km to 300 km. The orbit is determined by Global Positioning Sensing receivers on board each satellite, the distance between the satellites is measured with an accuracy of  $1\mu\text{m}$  and the accelerometers present a resolution of  $10^{-10} \text{ ms}^{-2}$ .

This technique can be improved by using drag-free satellites with inertial sensors and a laser tracking: the thrust of each satellite, provided by the propulsion system, is controlled in such a way that the satellite follows the mass of its inertial sensor without disturbing its motion; then, the laser beam between the two satellites reflects on the two falling masses and the variations of distance can be measured with a better performance.

Another possibility for improving the geodesy objectives of the GRACE mission, is the accommodation of a space gradiometer on board a drag-free satellite at an altitude lower than 300

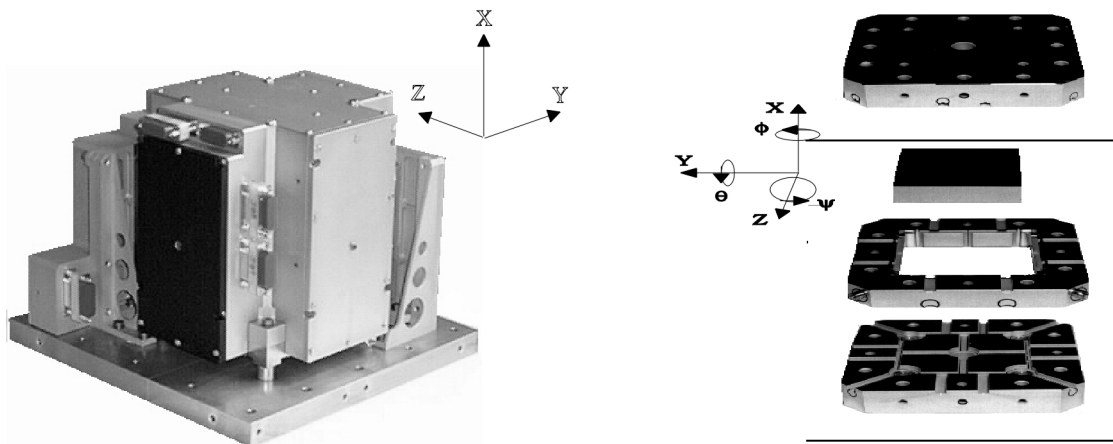

**Fig. 1-** STAR sensor unit before integration in the CHAMP satellite (right) and its internal core (left).

km (Rummel and Colombo, 1985), like in GOCE. The gravity gradiometer is composed of several identical acceleration sensors mounted on a rigid and stable structure. It can provide the fine measurements of the Earth's gravity gradient tensor components for the determination of the upper harmonics of the potential.

## 2. The STAR accelerometer for the CHAMP mission

The German CHAMP mission (CHALLENGING Micro-satellite Payload for geophysical research and application) is dedicated to observing the Earth with several scientific instruments : two magnetometers dedicated to the Earth's global magnetic field mapping, one digital ion-drift meter, to deliver complementary measurements of the Earth's electrical field, one GPS dual-frequency receiver, contributing to the atmospheric analysis, density, pressure and temperature sounding but devoted first to the precise orbit determination with centimetre accuracy, and, at last, the STAR (Space Three-axis Accelerometer for Research) accelerometer (Reiberg, 1995).

In October 1999 the CHAMP satellite is scheduled for launching by a Russian KOSMOS rocket at an altitude of 550 km, in a circular orbit with a 100 degree inclination, the eccentricity being less than 0.01. During the five-year mission, the orbitography will be finely performed and the accelerometer, integrated at the centre of mass of the satellite, with an accuracy of a few millimetres will measure the air drag, the solar and Earth radiation pressures and the attitude manoeuvre effects in a frequency bandwidth from DC to a few tenths of Hertz aiming at the Earth's gravity field recovery up to degrees and orders of about 50. A by-product of the accelerometer measurements will be the determination of the atmospheric density variations, in particular, at the lower altitude of the mission.

STAR is a six-axis accelerometer providing the three linear accelerations along the instrument sensitive axes and the three angular accelerations about these axes (see Fig. 1). STAR presents a measurement range of  $\pm 10^{-4}$  m/s<sup>2</sup> and exhibits a resolution of better than  $3 \cdot 10^{-9}$  m/s<sup>2</sup> for the y- and z-axes and  $3 \cdot 10^{-8}$  m/s<sup>2</sup> for the x-axis within the measurement bandwidth from  $10^{-4}$

Hz to  $10^{-1}$  Hz. The measurements are integrated over one second before delivery to the satellite data bus. The configuration of the instrument is compatible with ground tests which demand specific characteristics of the less accurate  $x$ -axis for the operation under one  $g$  gravity field. In orbit, STAR  $x$ -axis is vertical from the Earth, while the  $y$ -axis is normal to the orbit and the  $z$ -axis along track.

The concept of an electrostatic servo-controlled accelerometer like STAR, is well suited for space applications: the electrostatic forces give the possibility of generating very weak but accurate accelerations while the capacitive sensing offers a high-position resolution with negligible back-action. The accelerometer proof-mass is fully suspended with six servo-control loops acting along its six degrees of freedom, suppressing any mechanical contact to the benefit of the resolution, and yielding to a six-axis accelerometer.

The internal cage of the accelerometer, constituted by three electrode-plates made of silica glass, surrounds the solid parallelepiped proof-mass, of  $4 \times 4 \times 1$  cm sides and a 72 grams weight, made in Chromium coated Titanium alloy. The accelerometer's performance mainly depends on the stability, the cleanliness and the geometrical accuracy of the assembly that is integrated inside a tight housing which carries the accelerometer electronics in order to reduce the stray capacitances between the sensor core and the electrical circuits.

In operation, the mass is maintained motionless at the centre of the cage at a distance of  $60 \mu\text{m}$  along  $x$  and  $75 \mu\text{m}$  along  $y$  and  $z$  axes with a stability of  $2.5 \cdot 10^{-12} \text{ m}/\sqrt{\text{Hz}}$ , with an  $1/\sqrt{f}$  increase for frequencies lower than 1 Hz. The fine measurement of the voltages applied on the electrodes provide the accelerometer outputs. The major sources of noise have been evaluated and represented in Fig. 3.

After integrating the instrument in March 98, the STAR performance was tested as far as possible on the ground. Measurements of residual low-frequency vibrations of the testing platform (with the  $y$  and  $z$  axes maintained horizontal) were performed with a resolution of  $10^{-8} \text{ ms}^{-2} \text{ Hz}^{-1/2}$  at frequencies lower than 0.1 Hz corresponding to the requirement of  $3 \cdot 10^{-9} \text{ ms}^{-2} \text{ rms}$  in the measurement bandwidth (Fig. 3). The accelerometer low-level bias (less than  $10^{-5} \text{ ms}^{-2}$ ) was also verified in free-fall in the Bremen drop tower (Touboul, 1996).

### 3. From CHAMP to GRACE and the GOCE instrument

The STAR accelerometer design benefits from the experience of the previous ASTRE accelerometer that flew three times on board the Columbia shuttle in 1996 and 1997. The ASTRE instrument was very similar to STAR but with a full-scale range of 1 mg, more convenient for a manned Spacelab vibration environment (McPherson et al., 1999). The concept of both instruments, the technologies and materials involved, the electronic functions of the six servo-loops for the proof-mass control, are very similar. The only differences are a harder coating for the proof-mass and an explicit architecture of the loops to control the three translations and rotations.

For the future GRACE mission, the two SuperSTAR accelerometers are now defined and under development to meet a resolution of  $10^{-10} \text{ ms}^{-2} \sqrt{\text{Hz}}$ . The configuration is quasi-identical

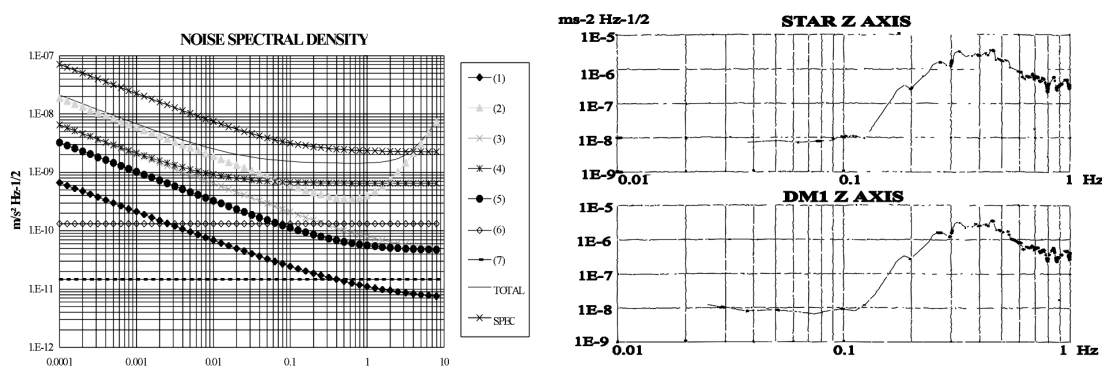

**Fig. 3** - STAR performance evaluation, y or z axis (on right) - (1) electrical disturbances; (2) position sensing; (3) electrostatic actuator; (4) contact potential difference; (5) measurement amplifier; (6) radiometer effect ; (7) gas damping - and resolution as demonstrated with ground tests (left).

to the STAR accelerometer. The instrument range is again reduced to a few  $10^{-5} \text{ ms}^{-2}$  by increasing the gaps between the mass and the electrodes,  $175 \mu\text{m}$  instead of  $75 \mu\text{m}$ , and by reducing the electrostatic actuator sensitivity. In fact, plus and minus drive voltages are applied to the electrodes with respect to opposite sides of the mass whose electrical potential is maintained at a dc biasing voltage. Then, the generated electrostatic force is proportional to the mass electrical potential that can be managed. Unfortunately, this *dc* level is the source of bias and bias fluctuations of the accelerometer, proportional to geometrical defects and to the inverse gap square. In the case of SuperSTAR, two different levels can be switched: the lower level is selected to reduce the full range and the bias and noise source, and the higher one is selected to increase the control authority when the mass has to be levitated at switch-on. These small modifications are sufficient to meet the specifications when considering the improved thermal control provided by the instrument case of the satellite,  $0.1 \text{ }^\circ\text{C}$  maximum variations per orbit. In particular, the stability of the scale factor and the accuracy of the dynamic response of the two accelerometers is mandatory for the comparison of the two satellite motions.

Even greater requirements of sensitivity and alignment matching are needed for the space gradiometry mission GOCE (Gravity and Ocean Circulation Explorer). The proposed electrostatic gravity gradiometer is composed of six accelerometers derived from SuperSTAR and accommodated on a very stable carbon-carbon structure in a diamond configuration, two accelerometers aligned along each axis. On board a drag-free satellite, at an altitude of 250 km, this full tensor gradiometer should provide the fine measurements of the Earth's gravity gradients with an accuracy of a few milli-Eötvös for the determination of the upper harmonics of the potential, up to order 300. The theoretical model of the accelerometer operation and the evaluation of performance based on the experimental results have been exploited to demonstrate the adequacy of these sensors to obtain resolution of better than  $10^{-12} \text{ ms}^{-2} \text{ Hz}^{-1/2}$  in the frequency bandwidth from  $5 \times 10^{-3} \text{ Hz}$  to 0.1 Hz. The range of the accelerometer can be reduced to  $3 \times 10^{-6} \text{ ms}^{-2}$  because of the drag compensation system of the satellite. The use of digital servo-loop electronics allows the selection of larger gaps (at least  $300 \mu\text{m}$ ) to the benefit of the performance

with the possibility of a very large increase of the control authority when necessary, and, in particular, when the drag-free system is not yet operant (Josselin et al., 1998). The gradiometer is accommodated inside a double insulated case with an active thermal control and the stability of the instrument temperature should be better than 1 mK over several orbits according to recent numerical simulations. Furthermore, as laboratory experiments have demonstrated, thanks to the configuration convenient for ground operation, the matching of the accelerometer sensitivity with a  $10^{-5}$  accuracy participates in a fine rejection of the gradiometer measurement of the satellite residual drag and angular motion effects (Willemenot et al., 1998).

#### 4. Conclusion and discussion

The proposed accelerometer for the GOCE mission is derived from the ASTRE, the STAR and the SuperSTAR instruments configuration, all being electrostatic accelerometers with contactless levitation of a solid mass made in Titanium or Platinum alloy. While the sensor core configuration is especially selected for space applications and optimized according to the weak level of acceleration to be sustained during each mission, it is nevertheless compatible with the ground testing of two of the three axes maintained horizontal during these tests. The resolution of the first three can be quasi-demonstrated on the ground. This is not the case for the gradiometer sensors that have to exhibit a resolution one hundred times better than the accuracy of the tests limited by the coupling with the one  $g$  vertical axis. This is why dedicated experiments have been performed to evaluate all the electronic functions and all the physical disturbances of the mass inside the accelerometer cage. These investigations lead to expected resolutions that are even better than those required by GOCE; and, in particular, in view of the inertial sensors of the future space gravity wave interferometer which requires acceleration specifications of  $10^{-15} \text{ ms}^{-2} \text{ Hz}^{-1/2}$  (Rodrigues, 1995). Both projects take advantage of a drag-free satellite environment but in the GOCE project the relative acceleration of the mass has to be measured directly by the sensors themselves, while in the LISA missions, the measurement is performed through the laser interferometer.

#### References

- Boudon Y., Barlier F., Bernard A., Juillerat R., Mainguy A. M., Walch J. J.; 1978: *Synthèse des résultats en vol de l'accéléromètre CACTUS pour des accélérations inférieures à  $10^{-9} g$* . Recherche Aérospatiale, No. 1978-6.
- Bougher S. W. et al.; 1990: *The Mars thermosphere 2. General circulation with coupled dynamics and composition*. J. Geophys. Res., **95**, 14 811-14 827.
- Chassefière E. et al.; 1998: *Projet DYNAMO*, séminaire des programmes scientifiques du CNES, Arcahon, Feb 1998.
- Folkner B. et al.; 1998: *Second LISA Symposium Proceedings*, Pasadena, July 98.
- Josselin V., Touboul P. and Willemenot E.; 1998: *Digital electronics for electrostatic accelerometers: interest for high resolution and in-orbit*. Same proceedings, Trieste, 98.
- Keating G. M. and the rest of the MGS Aerobraking Team; 1998: *The Structure of the Upper Atmosphere of Mars: In-situ Accelerometer Measurements from Mars Global Surveyor*. Science, **279**, 1672-1676.

- Marcos F. A. and Forbes J. M.; 1985: *Thermospheric Winds from the satellite electrostatic triaxial accelerometer system*, J. Geophys. Res., **90**, A7, 6543-6552.
- McPherson K. M., Nati M., Touboul P., Schütte A., Sablon G.; 1999: *A Summary of the Quasi-Steady Acceleration Environment On-Board STS-94 (MSL-1)*, AIAA, Reno, Jan 99.
- Nati M., Bernard A., Foulon B. and Touboul P.; 1994: *ASTRE, a highly performant accelerometer for the low frequency range of the microgravity environment*. 24th Symposium on space environmental control systems, Friedrichshafen Germany, 1994.
- Reigber C.; 1995: *CHAMP a challenging micro-satellite payload for geophysical research and application*, GFZ Final Report, Postdam Germany, 1995.
- Rodrigues M., Touboul P., Le Clerc G. M.; 1995: *The Inertial Reference Sensor CAESAR for the Laser Interferometer Space Antenna Mission*. Symposium on Fundamental Physics in Space, London, UK, 1995
- Rummel R. and Colombo O. L.; 1985: *Gravity field determination from satellite gradiometry*. Bull. Geod., **59**, 233-246.
- Touboul P. and Métris G.; 1998: *μSCOPE proposal for a satellite mission*. CNES, Feb 98.
- Touboul P. and Foulon B.; 1998: *Space accelerometer development and drop tower experiments*, Space Forum, 1998, Vol. 4, pp. 145-165.
- Touboul P., Foulon B. and Willemenot E.; 1996: *Electrostatic Space Accelerometers for Present and Future Missions*. IAF 96-J1-02, Beijing, Oct. 96, Acta Astronautica accepted, to be published.
- Willemenot E., Touboul P., and Josselin V.; 1998: *Gradiometer Calibration and Performance Verification: GOCE Approach*. Same proceedings, Trieste, Sept. 98.